

CAMMUS

CP5 踏板

CP5 PEDAL

使用说明书

USER'S MANUAL



使用前须知事项

使用本产品前，请先仔细阅读本指南，并妥善保存，以备将来参考之用。家长及监护人应详读本指南并确保儿童遵守安全注意事项。

关于安全

本产品是在充分重视安全性能的情况下设计的，但仍然需要用户自行遵守基本使用规则，为确保安全，请遵守以下各项规则：

- * 仅能在远离水源和潮湿环境运行。
- * 仅能接入100-240V电压，且需保证电源接地良好。
- * 拆装设备请务必确保设备在断电状态下。
- * 禁止设备在高温状态（ $\geq 60^{\circ}\text{C}$ ）下运行，高温时请勿触摸机壳表面。
- * 在不使用设备或者离开设备时请务必关机。
- * 禁止敲击碰撞和擅自拆开设备。
- * 禁止使用非官方出厂的电源适配器，天线等附件。
- * 禁止带电插拔设备上的所有接口（电源，Type-C，天线等）。

免责声明与警告

- *本产品并非玩具，未满18岁请在成人陪同下使用。在有儿童出现的场景操作时请务必特别小心注意。
- *请务必在使用产品之前仔细阅读本文档和《用户手册》，了解您的合法权益、责任和安全说明；否则，可能带来财产损失、安全事故和人身安全隐患。一旦使用本产品，即视为您已理解、认可和接受本文档全部条款和内容。使用者承诺对自己的行为及因此而产生的所有后果负责。使用者承诺仅出于正当目的使用本产品，并且同意本文档全部条款和内容及CAMMUS可能制定的任何相关政策或者准则。
- *CAMMUS不承担因用户未按本指引《用户指南》使用产品所引发的一切损失，由此产生的设备损坏，CAMMUS有权拒绝保修。
- *在遵从法律法规的情况下CAMMUS享有对本文档的最终权。CAMMUS有权在不事先通知的情况下，对本条款进行更新，改版或终止。

注意事项



为了您更方便快捷的使用CP5 踏板，请您在安装使用前务必认真阅读本说明手册，它包含重要的产品与安全信息；请保留此手册以便后续有需要进行参考。

安全用电

严禁将设备和电源置于潮湿或雨水环境中，以避免造成设备短路、损坏及火灾、电击等危险。

包装清单

制动踏板	*1
油门踏板	*1
底板	*1
踏板掌	*2
防滑垫	*2
Type-C数据线	*1
紧固螺丝包	*1
保修卡+说明书	*1

外形尺寸概况

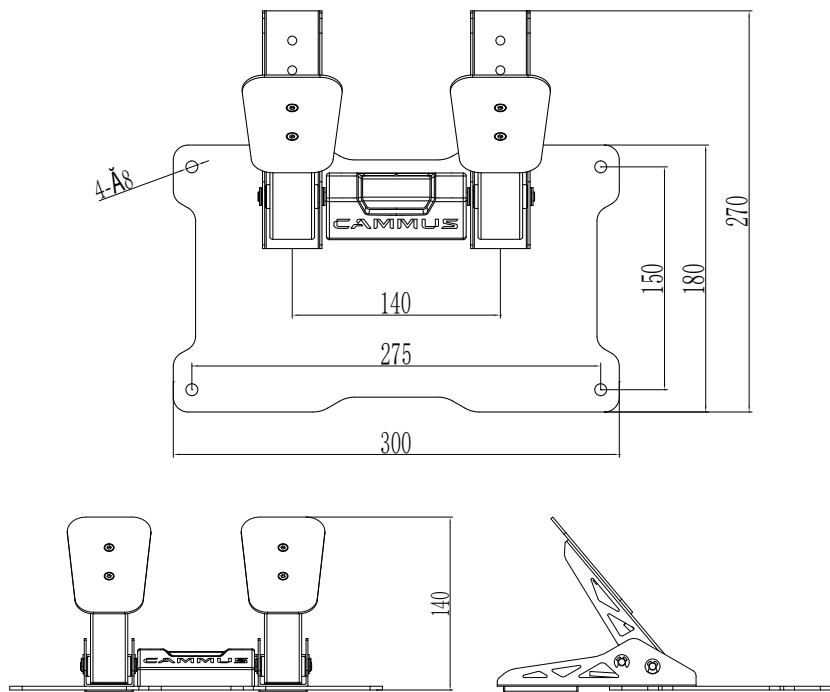

基本数据	
长宽高	270*300*140mm
机重	2.4Kg
传感器形式	霍尔
材质	冷轧钢

支持PC主流赛车游戏

要求 (PC): Windows10, 150 MB 可用硬盘空间, USB 2.0 端口

踏板接口详情：

接口详情参看图纸说明，如图所示；

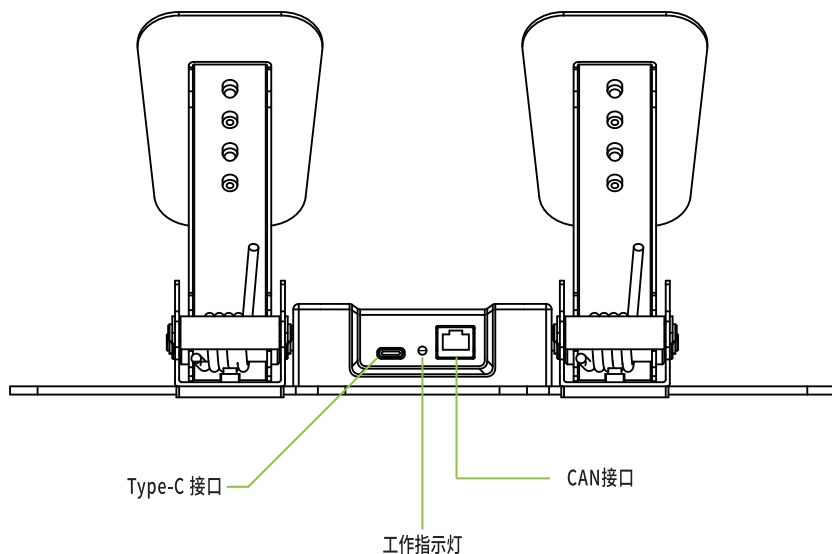

Type-C：直接接入主机设备即可识别使用

工作指示灯：长亮时处于工作状态

CAN：接入CAMMUS具备输出CAN信号的设备可识别使用

踏板组装说明：

包装位置详情参看图纸说明，如图所示；

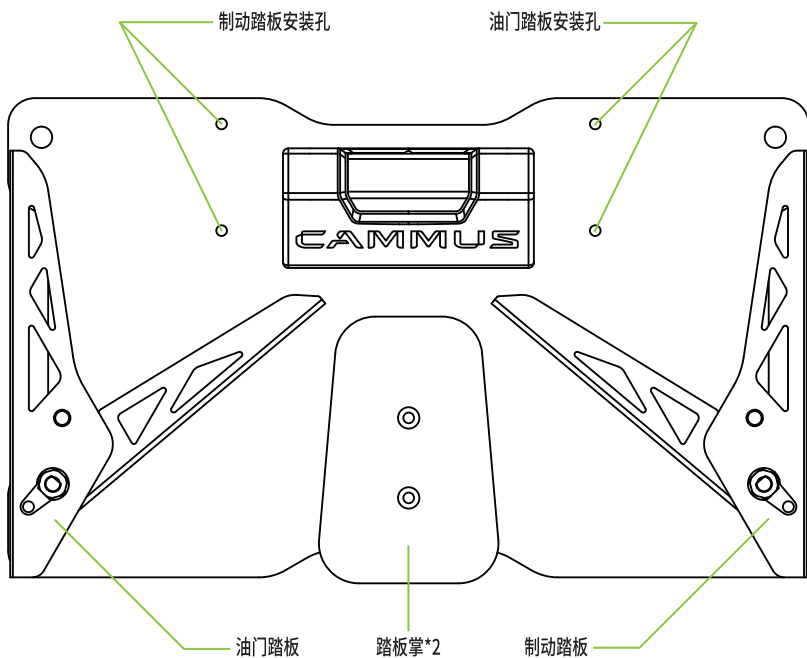

CP5踏板首次使用时需接入PC端软件重置初始值：组装完成后接入设备，然后启动CAMMUS应用，进入设备设置踏板极值，即最大最小的踏板行程对应的数据。

安装步骤：



图1：取出制动踏板及油门踏板，校对安装孔位；



图2：将踏板放置于底板上，突出的转轴对准底板盒子的开口并推入开口内，用M4*10的沉头螺栓从底部向上锁紧，孔位以A-a，B-b，C-c，D-d的顺序对齐即可锁紧；

3

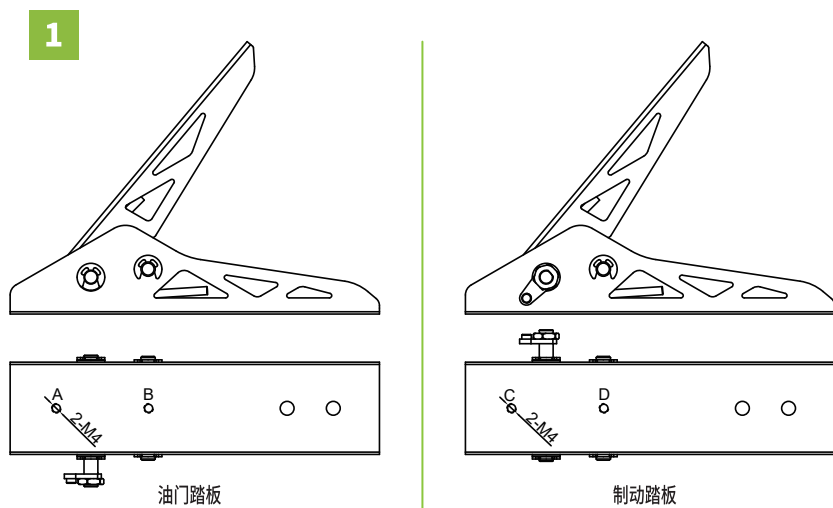

图3：踏板面的安装可根据个人需求选择安装孔位，取4颗M3*6的沉头螺栓对齐锁紧即可；

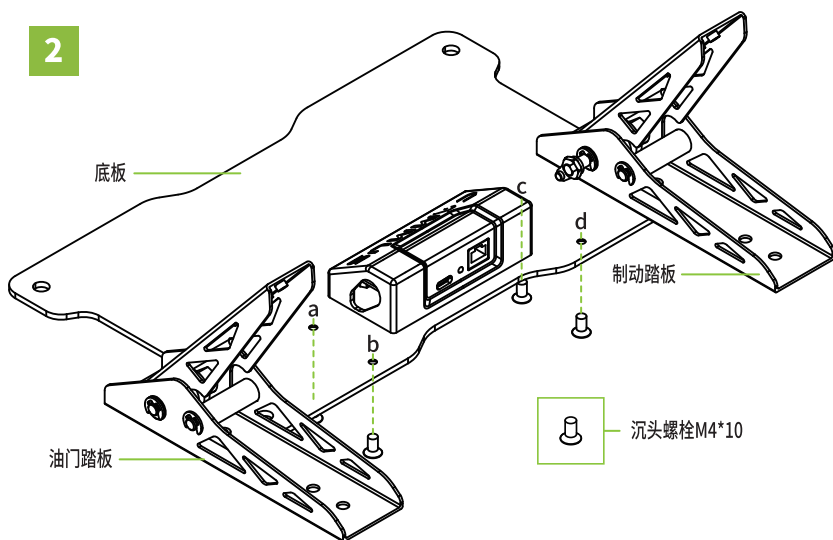
4

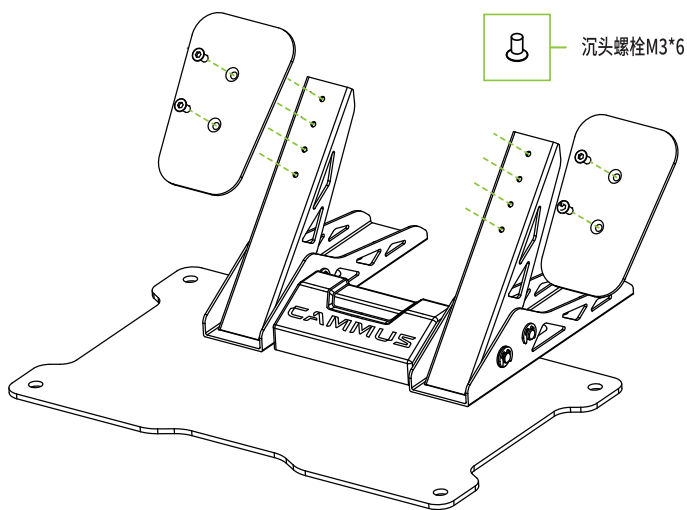

图4：取出防滑贴，撕掉贴膜后贴在踏板与底板未重合的悬空位置；

5

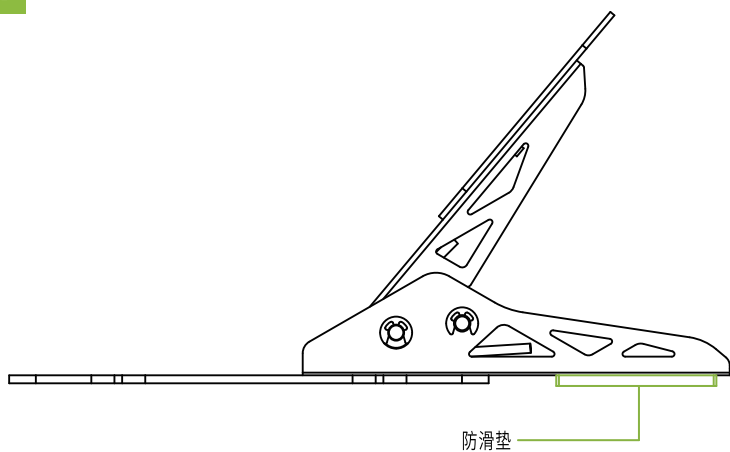

图5：可翻转踏板底板粘贴防滑垫，油门踏板和制动踏板各粘贴一片，即可完成组装。

控制软件获取

用户可通过以下方式获取控制软件[CAMMUS]，可对CP5踏板进行参数调节及设备管理。

- 桌面端软件的获取：

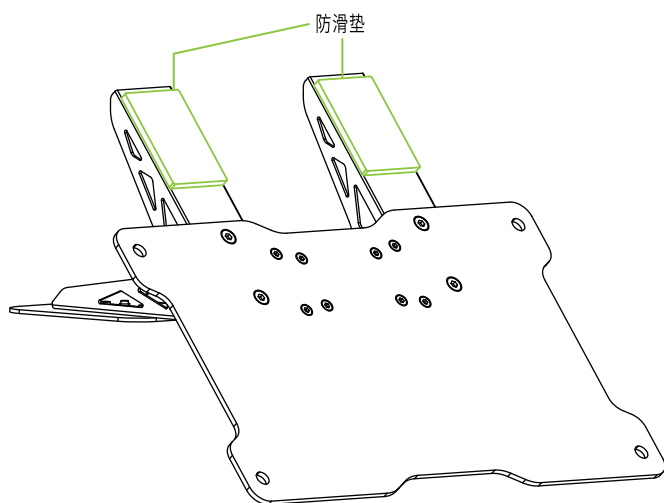
(<https://cammus.com.cn/download/>) 下载最新桌面端并安装；

- 移动端软件的获取：



苹果移动端
APP下载



- 向卡妙思指定销售网点及渠道联系客服可以获得下载文件。

固件更新

为保证用户的最佳体验，请将您的固件更新至最新版本。

用户可通过以下方式更新：

- 用户可通过最新桌面端的固件升级功能对设备固件进行更新；
- 如有疑问，通过电话向官方工作人员咨询：0755-86259940

保修说明

本产品保修时间为1年，只在中国境内大陆地区有效（除台湾、澳门、香港地区），凭借产品保修卡以及购买产品的有效发票或规定的其他有效凭证，用户可以在有效时间内享受到保修服务。为了您能享受到CAMMUS的保修支持，请勿人为对机器造成损坏，请勿脱离官方或官方授权相关人员的指导进行对机器或系统的非正常使用操作。

服务规定

- 保修卡丢失不补发，请妥善保管，在需要维修服务时请出示；
- 保修卡不承担其他责任，包括但不限于偶尔发生的或随之而来的损坏或预计会得到的利益或利润的损失、由于使用或无法使用产品导致的工作停止或损坏等情况下的任何责任；
- 维修服务中更换下来的零件，均不交还用户；
- 维修服务有效期的计算方法以购买之日起为准；
- 保修卡中记载的内容如有与国家相关法律法规不符之处，以国家相关法律法规的规定为准。

不实行保修服务的情况

- 不能出示有效发票或/及保修规定的其他有效凭证和保修卡的；
(根据三包规定能够证明产品在保修有效期内的除外)
- 保修卡有涂改痕迹或记载的产品信息与产品实物不符的；
- 产品上条形码被损或有涂改痕迹的；
- 消耗材料的自然消耗、磨损及老化的；
- 雷击或其它用电系统原因造成故障的；
- 事故、灾害、战争等不可抗力因素造成故障的；
- 因用户行为(自行改装、修理、或由非卡妙思授权的第三方拆动、改装、维修等)而损坏的；
- 与产品一同使用的非产品自身配置的外设或附件的软件故障及其导致产品

故障的；

- 非产品预装的第三方软件的使用故障及其导致产品故障的；
- 用于产品说明未明确声明与该产品兼容的产品而故障、损坏的；
- 由于进液、受潮、外力挤压、掉落等使用或保管不当造成故障的；
- 使用盗版软件或在使用过程中感染病毒造成故障的；
- 超过保修有效期的；
- 未按产品使用说明要求使用、维护、保管而造成故障的；
- 非卡妙思经销之产品的。

补充说明

*首次使用或体验您的设备的人士须有该设备所有者进行指导。

*头发、电缆、裙摆等宽松衣物或其他易缠结物应远离模拟器。

*用户使用本产品进行模拟游戏活动,建议游戏结束30分钟后驾驶汽车。

*本说明手册仅作为单款产品(包括单款产品下不同款式)通用说明手册,在本手册中演示产品仅作为产品说明不作销售说明使用,具体款式产品以用户购买的为准。

感谢您的阅读,祝您使用愉快。

本手册如有更新,恕不另行通知。您可以在CAMMUS官方网站及官方信息发布平台查询最新版本《用户手册》及其他资讯。

www.cammus.com如您对本说明手册及CAMMUS全系产品有任何疑问和建议,请通过信息渠道联系我们。

再次感谢您对CAMMUS的支持!

Precautions before use

Before using this product, please read this guide carefully and keep it for future reference. Parents and guardians should read this guide carefully and ensure that children Observe safety precautions.

About security

This product is designed with full emphasis on safety performance, but users still need to abide by the basic rules of use. To ensure safety, please follow the

following rules:

- *Only operate away from water and wet environment.
- *Only 100-240V voltage can be connected, and it is necessary to ensure that the power supply is well grounded.
- *Please ensure that the device is powered off when disassembling the device.
- *It is forbidden to operate the device at high temperature ($\geq 60^{\circ}\text{C}$), and do not touch the surface of the case when it is high temperature.
- *Be sure to turn off the device when not in use or when leaving the device.
- *It is forbidden to knock, collide or disassemble the device without authorization.
- *The use of unofficial power adapters, antennas and other accessories is prohibited.
- *It is forbidden to plug and unplug all interfaces (power supply, USB, antenna, etc.) on the device while the power is on.

Disclaimer and Warning

*This product is not a toy, please use it under the accompaniment of an adult if you are under the age of 18. Be especially careful when operating in scenes where children are present.

*Be sure to read this document and the User Manual carefully before using the product to understand your legal rights, responsibilities and safety instructions; otherwise, property losses, safety accidents and personal safety hazards may occur. Once you use this product, you are deemed to have understood, approved and accepted all the terms and contents of this document. Users promise to be responsible for their actions and all consequences arising therefrom. The user promises to use this product only for legitimate purposes, and agrees to all the terms and content of this document and any relevant policies or guidelines that CAMMUS may formulate.

*CAMMUS is not responsible for all losses caused by users not using the product in accordance with this "User Guide", and CAMMUS has the right to refuse warranty for equipment damage caused by this.

*CAMMUS reserves the final right to this document in compliance with laws and regulations. CAMMUS has the right to update, revise or terminate this clause without prior notice.

Precautions



In order to use the CP5 Pedal safely and properly, please read this instruction manual carefully before installation and use. It contains important product and safety information; please keep this manual for future reference.

Electricity safety

Do not place the device in a humid or rainy environment to avoid short-circuiting, damage, fire, electric shock and other risks.

Packing list

Brake pedal	*1
Accelerator pedal	*1
Bottom plate	*1
Pedal palm	*2
Non-slip mat	*2
Type-C cable	*1
Hardware package	*1
Warranty card + manual	*1

Dimension overview

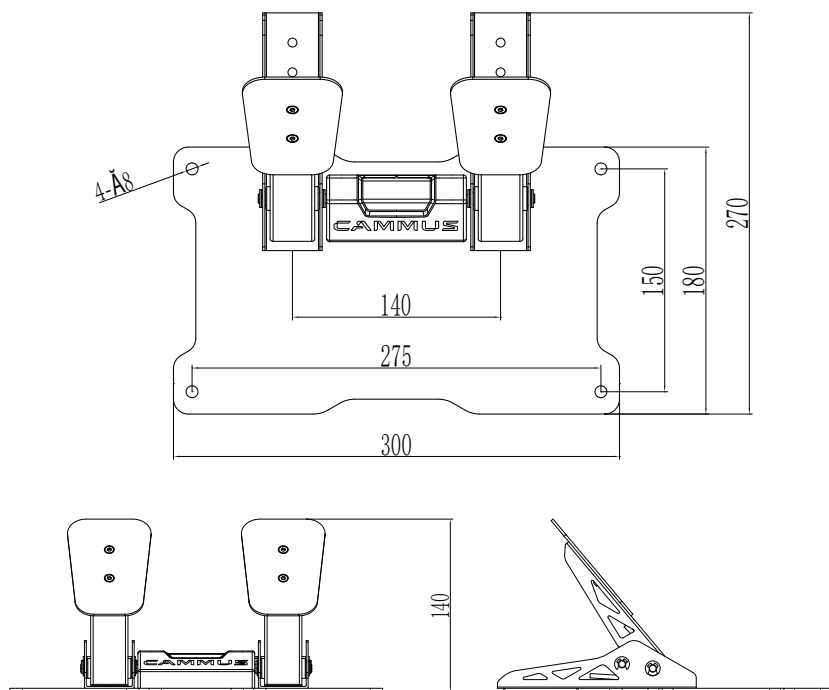

Basic Data	
Length, width and height	270*300*140mm
Bare weight	2.4Kg
Sensor form	Hall
Pedal material	cold rolled steel

Support PC mainstream racing games

Requirements (PC): Windows 10, 150 MB free hard disk space, USB 2.0 port

Pedal socket details:

For interface details, refer to the drawing description, as shown in the figure.

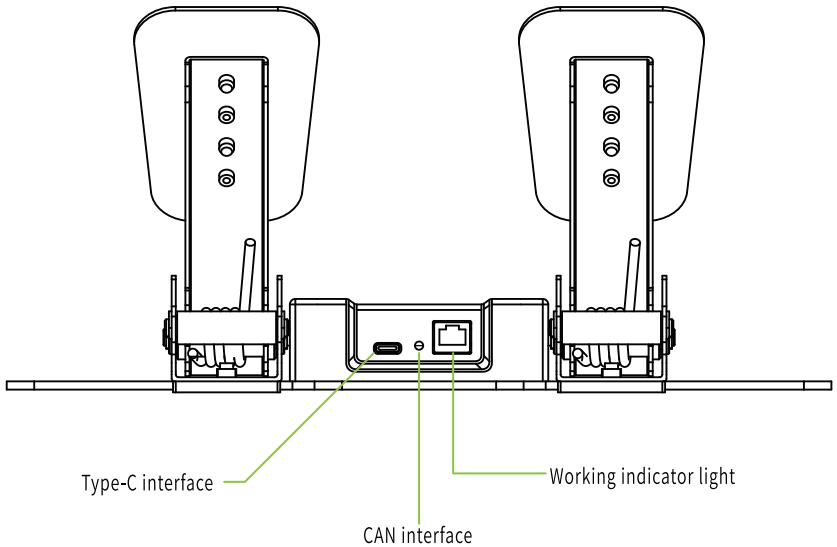

Type-C interface: Its identified and used by directly connecting to the host device.

CAN interface: Its identified and used by connecting to a CAMMUS wheelbase.

Working indicator light: Its in working state when its actively on.

Pedal Assembly Instructions:

Please refer to the drawing description for details of the packaging position, as shown in the figure.

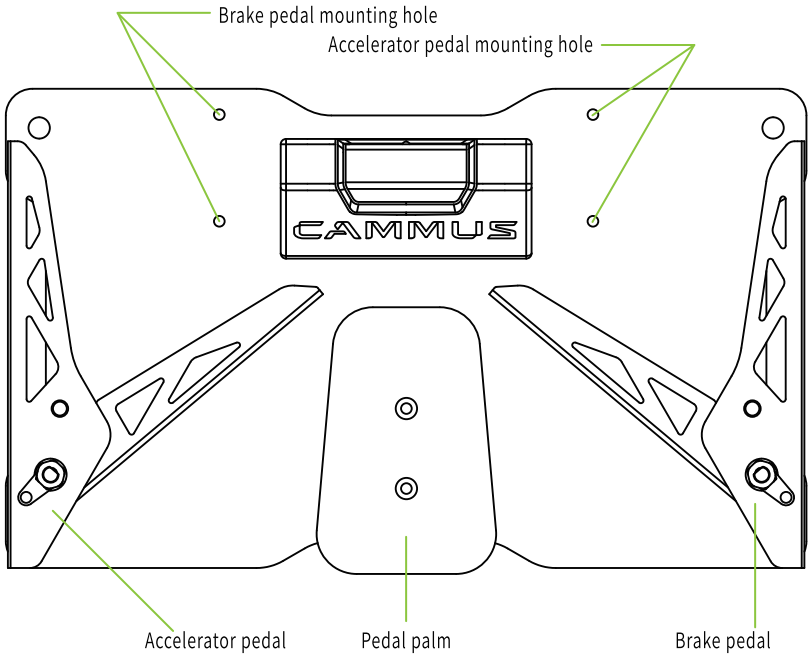

When the CP5 pedal is used for the first time, it needs to be connected to the PC software to reset the initial value. After the assembly is completed, connect to the device, then start the CAMMUS application, enter the device and set the pedal extreme value by pressing the pedals all the way to their furthest position.

installation steps:

1

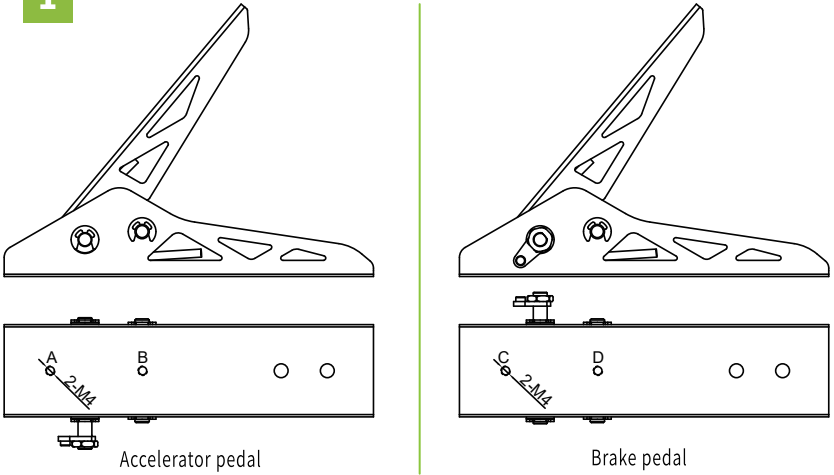

Figure 1: Take out the brake pedal and accelerator pedal, and check the mounting holes.

2

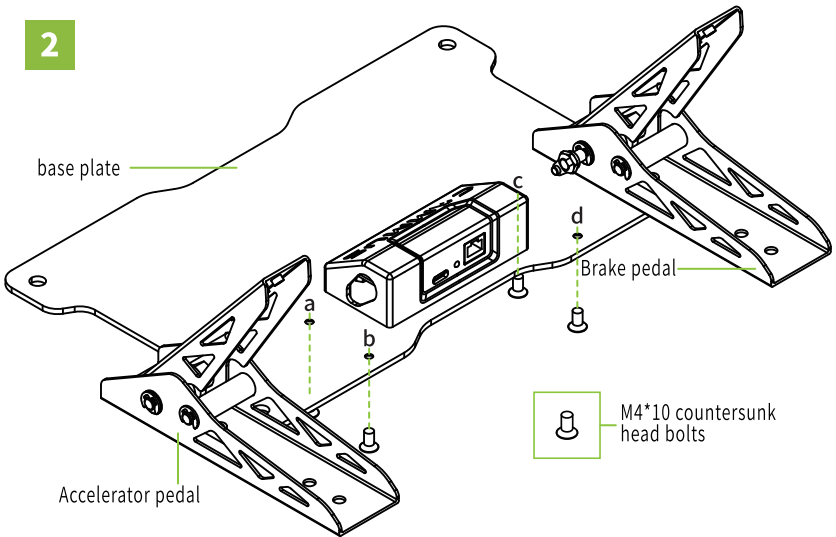

Figure 2: Place the pedal on the base plate, align the protruding shaft with the opening of the base plate box and push it into the opening. Use M4*10 countersunk head bolts to lock from the bottom up, align the holes in the order of A-a, B-b, C-c, D-d to lock.

3

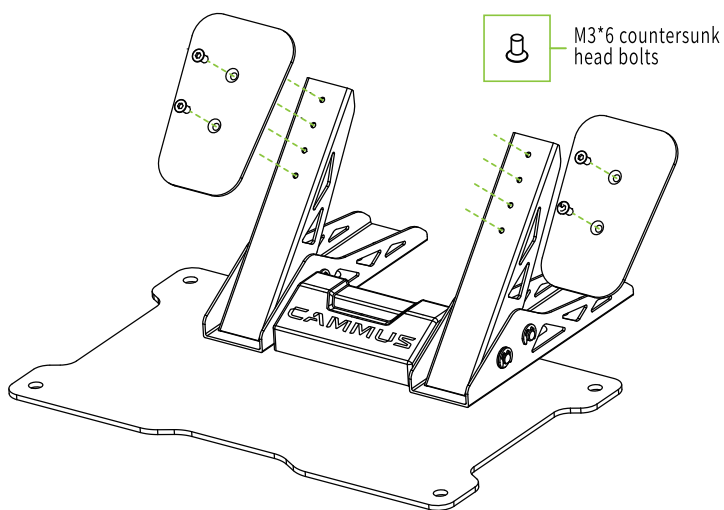

Figure 3: The pedals can be placed where the user is most comfortable with, then take 4 M3*6 countersunk head bolts to align and attach them in place.

4

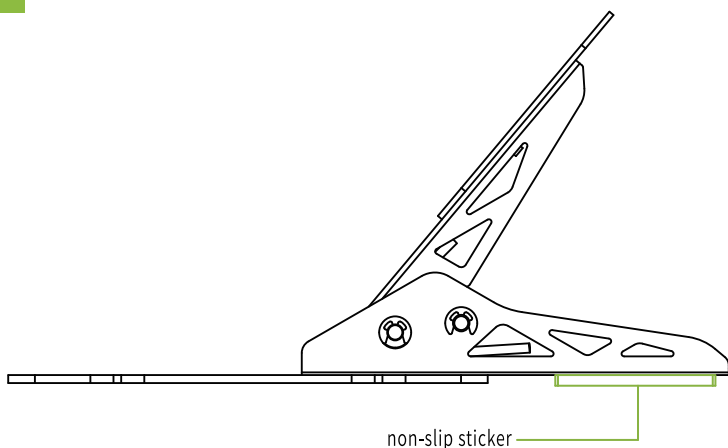

Figure 4: Take out the non-slip sticker, tear off the film and paste it on the suspended position where the pedal and the bottom plate do not overlap.

5

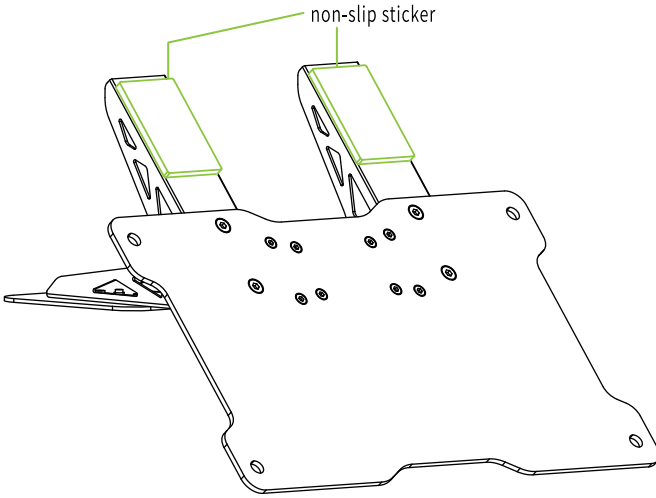

Figure 5: Paste anti-slip pads on the bottom plate of the reversible pedal, and paste one piece each on the accelerator pedal and brake pedal to complete the assembly.

APP acquisition and usage tutorial

Users can obtain the [CAMMUS] control software through the following methods, Desktop software:

- Desktop software:
(cammusracing.com) download the latest and install it.
- Mobile software:



Apple mobile
download



Contact customer service at the designated CAMMUS sales outlets and channels to obtain the download file.

Firmware update

To ensure the best user experience, please update your desktop and firmware to the latest version.

Users can update by:

- Enter CAMMUS official website (cammusracing.com) to download and install the latest desktop.
- Users can update the device firmware through the latest desktop firmware upgrade function.
- If you have any questions, please consult us by email: media@cam-mus.com

Warranty

The warranty period of this product is 1 year(except EURO,which is 2 years). With the product warranty card, valid invoice or/and other valid certificates for purchasing the product, users can enjoy the product within the valid period. In order for you to enjoy the warranty support of CAMMUS, please do not artificially damage the machine, and do not operate the machine or system abnormally under the guidance of the official or official authorized personnel.

Service Regulations

- The warranty card will not be reissued if it is lost, please keep it properly and present it when repair service is required.
- The warranty card does not assume other responsibilities, including but not limited to any accidental or consequential damage or loss of expected benefits or profits, work stoppage or damage due to use or inability to use the product, etc. responsibility.
- The parts replaced in the maintenance service will not be returned to the user.
- The calculation method of the validity period of the maintenance service is based on the date of purchase.
- If there is any discrepancy between the content recorded in the warranty card and the relevant national laws and regulations, the relevant national laws and regulations shall prevail.

Cases where warranty service is not performed

- Unable to produce valid invoices or/and other valid certificates and warranty cards stipulated in the warranty. (except for those that can prove that the product is within the validity period of the warranty according to the Three Guarantees regulations)
- The warranty card has traces of alteration or the recorded product information is inconsistent with the actual product.
- The barcode on the product is damaged or has traces of alteration.
- Natural consumption, wear and aging of consumable materials.
- Faults caused by lightning strikes or other electrical system reasons. Failures caused by force such as accidents, disasters, and wars.
- Damaged due to user behavior (self-refitting, repairing, or dismantling,

refitting, repairing, etc. by a third party not authorized by CAMMUS).

- Software failure of peripherals or accessories that are not configured by the product itself and cause product failure.
 - The use of third-party software that is not pre-installed on the product fails and causes product failure.
 - It is used for failure or damage of products whose product instructions do not clearly state that they are compatible with the product.
 - Faults caused by improper use or storage such as liquid damage, dampness, external force extrusion, drop, etc.
 - Using pirated software or infecting with viruses during use causes malfunctions.
 - Beyond the validity period of the warranty.
 - Failure to use, maintain, and store according to the product instructions.
- Products not distributed by CAMMUS.

Supplementary Note

*People who use or experience your device for the first time must be guided by the owner of the device.

*Hair, Loose clothing, cables, skirts, or other objects easily damaged or wrapped around wheel, should be kept away from the simulator.

*For users who use this product for simulated game activities, it is recommended to drive the car 30 minutes after the game is over.

*This instruction manual is only used as a general manual for a single product.

*The products demonstrated in this manual are only used as product descriptions and not as sales instructions.

The specific styles of products are subject to the purchase of the user.

*This manual is subject to update without prior notice. You can check the latest version of "User Manual" and other information on the CAMMUS official website and official information release platform.

www.cammusracing.com If you have any questions or suggestions about this instruction manual and all CAMMUS products, please contact us through information channels.

Thank you again for supporting CAMMUS!



CAMMUS

合格证

CERTIFICATE

产品型号: _____
Product number

检验员: _____
Inspector:

生产日期: _____
Production Date:

CAMMUS